

SUR



Directory of Participants

PRIS

2nd Automation + Robotics Expo

INGLY

25. - 27. April 2026 | Athens, Greece

INGE

www.advantageaustria.org

NIOUS

Meet 5 leading Austrian companies specializing in machine and occupational safety, enterprise modeling software, drive technology for mechanical and plant engineering, business development services, and extrusion crossheads for the cable industry — all seeking new cooperation opportunities in Greece.



ADVANTAGE AUSTRIA
AUSTRIAN EMBASSY – COMMERCIAL SECTION
Christoph Sturm
The Austrian Trade Commissioner
Vas. Sofias 79
GR-115 21 Athens
T +30 210 884 37 11
E athen@advantageaustria.org
W www.advantageaustria.org/gr



Thank you for visiting the ADVANTAGE AUSTRIA stand at the 2nd Automation and Robotics Expo. We are pleased to participate for the first time in this leading platform for industrial automation, robotics and smart manufacturing technologies in Greece.

Five innovative Austrian companies are represented at our stand, showcasing solutions in areas such as machine and occupational safety, enterprise modeling software, drive technology for mechanical and plant engineering, business development services, and extrusion crossheads for the cable industry. What they all have in common is a strong focus on quality, reliability and practical, application-oriented solutions, as well as a clear interest in developing new cooperation opportunities in Greece.

Greece is undergoing a significant transformation of its industrial base. Investments in automation, efficiency and advanced production technologies are becoming increasingly important, creating attractive opportunities for international technology partnerships.

Austrian companies are well positioned to support this process, drawing on long-standing industrial expertise, high engineering standards and extensive international project experience.

We are here to underline our commitment to strengthening bilateral cooperation and fostering sustainable technology partnerships between Austria and Greece.

Let me conclude by wishing you successful collaborations with our participating Austrian companies.

Καλές δουλειές!

Yours sincerely,

Christoph Sturm
The Austrian Trade Commissioner

PARTICIPATING COMPANIES



Machine and occupational safety



Enterprise modeling software



Drive technology for mechanical and plant engineering



Business development services



Extrusion crossheads for the cable industry



AVS - Schmersal Vertriebsgesellschaft m.b.H.

Wienerbergstraße 9, 1100 Vienna

T +43 1 610280

E info@avs-schmersal.at

W www.schmersal.at



The Schmersal Group is one of the world's leading specialists in machine safety, offering a comprehensive portfolio of safety solutions for the protection of both people and machinery.

Through tec.nicum, Schmersal supports companies with consulting, engineering and qualification services – from risk assessment to CE conformity.

The tec.nicum academy complements this offering with practice-oriented training programmes on standards and machine safety.

In this way, Schmersal delivers holistic solutions ranging from safety components to knowledge transfer – ensuring Excellence in Safety worldwide.



© AVS - Schmersal Vertriebs G.m.b.H.

MACHINE SAFETY SOLUTIONS AND SERVICES

From Safety Components to Compliance and Training

The Schmersal Group offers international partners and industrial customers comprehensive machine safety solutions, combining high-quality safety components with consulting, engineering and qualification services via tec.nicum as well as practice-oriented training through the tec.nicum academy. This integrated approach supports machine manufacturers and operators in achieving regulatory compliance, reduced risk and sustainable safety excellence across the entire machine life cycle.

Industry: Plant Engineering & Construction / Smart Factory

Company is looking for: customers



BOC Products & Services AG

Operngasse 20b, 1040 Vienna

T +43 1 90510710

E [voc@voc-group.com](mailto:boc@voc-group.com)

W www.voc-group.com

Subsidiary in Greece:

BOC Information Technologies Consulting Ltd.

Avlidos 5 & Kesarias 16, 11527 Athens

T +30 222130 8676

E office@voc-gr.com

W www.voc.gr



BOC Group has over 30 years of experience in developing, implementing, and consulting using our EA and BPM solutions. BOC develops software products and services for effective and extensive management of all capabilities and assets in your organization.

The focus lies on improving Enterprise Architecture with ADOIT and Process Management capabilities with ADONIS, as well as facilitating better Governance and Compliance with ADOGRC.



BOC Greece, headquartered in Athens builds on the 20+ years of experience in the Greek market and incorporates BOC expertise within its network of local partners.

PROVISIONING OF PRODUCTS AND SERVICES

Providing ADONIS, ADOIT and ADOGRC to enable organizations to deliver better value to their clients

BOC Greece offers its software products ADONIS (BPM), ADOIT (EAM) and ADOGRC (GRC) and a range of services and leading practices, including training, consulting, coaching and customization, tailored to the Greek market.

Built on more than two decades of project experience and close cooperation with top universities, BOC may act as an accelerator for striving towards your company's objectives.

Industry: Software & IT, Engineering, Telecommunication

Company is looking for: customers

© BOC Products & Services AG



Lenze Austria GmbH

Ipflandesstrasse 1, 4481 Asten

T +43 7224 210-0

E Info.AT@Lenze.com

W www.lenze.at

Subsidiary responsible for Greece:

Lenze Zadvizhvasta Tehnika EOOD

Bld. Kuklensko Shose, VGR Building, 4004 Plovdiv

T +35 932 940 373

E martin.kamenov@lenze.com

W www.lenze.bg



Lenze is a leading drive technology specialist for mechanical and plant engineering. For more than 75 years, the company has been a pacesetter and strong partner at its customers' side.

By combining the three key areas of electromechanics, electronics and software, Lenze supports its customers, helping them to optimise production and logistics processes, reduce costs and lower their energy consumption.



**MARKET ENTRY IN GREECE:
PARTNERSHIPS FOR DRIVE TECHNOLOGY & AUTOMATION**

Lenze is looking for strong mechanical engineering and automation partners for innovative drive solutions

Lenze Austria and Lenze Bulgaria are specifically seeking new customers and partners in Greece at the Automation + Robotics Expo 2026, particularly mechanical engineering companies and system integrators. The focus is on applications in industrial equipment, consumer goods, intralogistics, HVAC-R, the packaging industry and material handling.



As "Best in Motion" we provide comprehensive solutions for all motion applications – from geared motors and frequency inverters to servo drives.

Industry: Plant Engineering & Construction / Smart Factory

Company is looking for: customers



Ruttensteiner GmbH - Market Entry Austria

Zenndorf 7, 4551 Ried im Traunkreis

T +43 720 3037350

E info@ruttensteiner.com

W www.ruttensteiner.com



Ruttensteiner Consulting - Market Entry Austria supports customers from all over the world in entering the Austrian market.

The services of Ruttensteiner Consulting - Market Entry Austria include: company formation, employment permits and visas, sales support, opening bank accounts, accounting and payroll as well as location search.

With 30 years of experience and expertise as a local service provider, Ruttensteiner Consulting - Market Entry Austria is your central contact for all your business concerns in Austria.

YOUR NEW BUSINESS LOCATION IN AUSTRIA

Ruttensteiner Consulting - Market Entry Austria is your central point of contact!

Are you intending to establish a new company location in Austria? Do you wish to relocate employees to Austria or start a new company in Austria?

Ruttensteiner Consulting - Market Entry Austria will support you with all your concerns and act as your competent and confidential point of contact.

Industry: Consulting, Engineering

Company is looking for: customers





UNITEK Maschinenbau- und Handels GmbH

Josef Österreicher Gasse 35, 1230 Vienna

T +43 1 332 55100

E office@unitek-crossheads.com

W www.unitek-crossheads.com

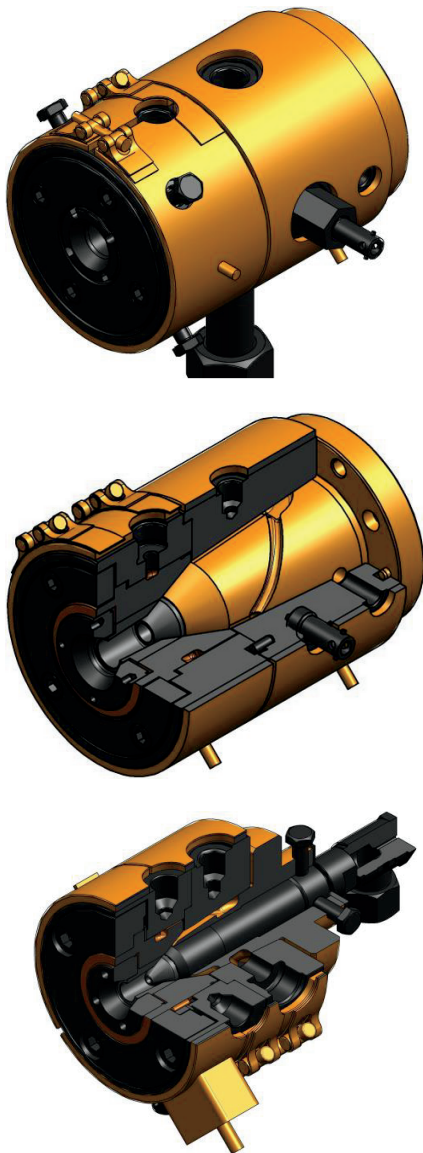

UNITEK is a leading global manufacturer of extrusion crossheads for the cable industry. For over 40 years, the focus has been on quality, precision and innovation. Research and close cooperation with users result in practical solutions. The system-based technological advantage: UNITEK modular crosshead systems offer long service life, simple operation and high flexibility - from standard applications to high-end solutions.

Products:

- Crossheads for single-layer to three-layer extrusion
- Solutions for ribbon cables and ultra-thin wires (from 0.04 mm)
- High-temperature crossheads
- Tools made from steel, carbide, diamond and UNALLOY
- Bypass systems
- Colour changing and cleaning systems
- Consulting & engineering for individual projects

EFFICIENT SOLUTIONS FOR MAXIMUM PERFORMANCE

Whether new plants, modernisation or special solutions are called for – UNITEK supports its customers from the initial concept to mass production. Its customer base includes leading production lines, cable factories and specialist companies. A worldwide sales and service network in over 60 countries ensures personal customer support, short response times and maximum customer satisfaction.

Industry: Engineering, Plant Engineering & Construction / Smart Factory, Chemicals / Plastics, Metals / Metal processing

Company is looking for: customers

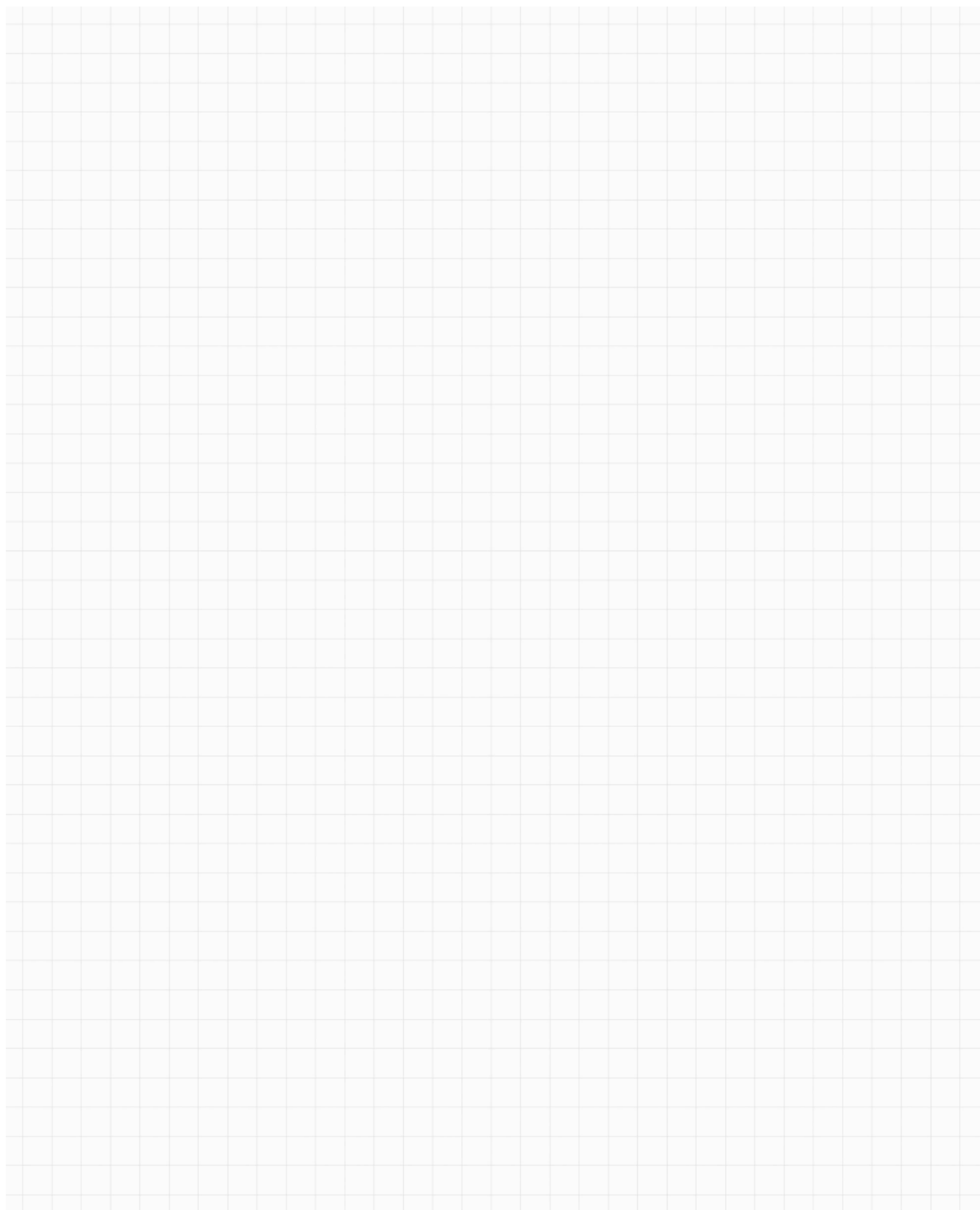

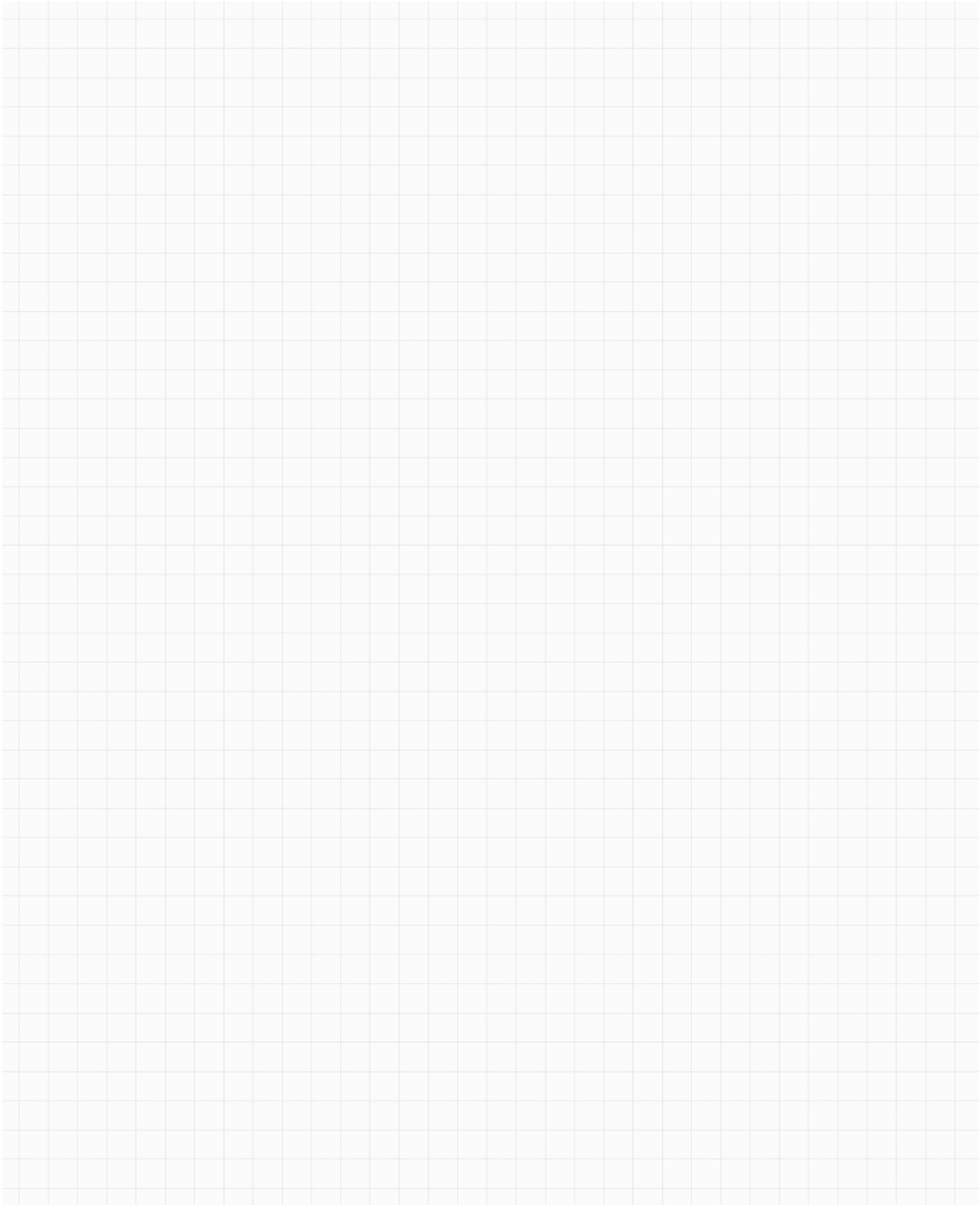

powered by:

